

Electronic overload relays

22A Inverse time characteristics



Description

- Wide and adjustable current range
- Adjustable trip time (trip class 5-10-15-20-30)
- Designed suitable for use with contactors
 - Directly mountable on the GM-9, 12, 18, 22 contactors
 - Separate mount versions are also available
 - Separately mountable on 35mm DIN rail or with screws
- 1NO+1NC trip contacts
- Manual reset as standard (Automatic reset optional)

Extended protective functions

Number of sensors		2CT	3CT	3CT
Types (GMP22-□)		(-2P, -2T, -2S)	(-3P, -3T, -3S)	(-3PR, -3TR, -3SR)
Functions	Overcurrent	✓	✓	✓
	Phase loss	✓	✓	✓
	Locked rotor	✓	✓	✓
	Phase unbalance		✓	✓
	Phase reversed			✓

Selection

Mount/Connection	Sensor	Setting range	Catalog No.
Directly on a contactor	2-sensor (2 CT)	0.3 - 1.5A	GMP22 - 2P · 1.5
		1 - 5A	GMP22 - 2P · 5
		4.4 - 22A	GMP22 - 2P · 22
	3-sensor (3 CT)	0.3 - 1.5A	GMP22 - 3P · 1.5
		1 - 5A	GMP22 - 3P · 5
		4.4 - 22A	GMP22 - 3P · 22
3-sensor Reverse phase detection	0.3 - 1.5A	GMP22 - 3PR · 1.5	
	1 - 5A	GMP22 - 3PR · 5	
	4.4 - 22A	GMP22 - 3PR · 22	
Separate mount ①	2-sensor (2 CT)	0.3 - 1.5A	GMP22 - 2S · 1.5
		1 - 5A	GMP22 - 2S · 5
		4.4 - 22A	GMP22 - 2S · 22
Cable connection with a screw ②	3-sensor (3 CT)	0.3 - 1.5A	GMP22 - 3S · 1.5
		1 - 5A	GMP22 - 3S · 5
		4.4 - 22A	GMP22 - 3S · 22
	3-sensor Reverse phase detection	0.3 - 1.5A	GMP22 - 3SR · 1.5
		1 - 5A	GMP22 - 3SR · 5
		4.4 - 22A	GMP22 - 3SR · 22
Separate mount ①	2-sensor (2 CT)	0.3 - 1.5A	GMP22 - 2T · 1.5
		1 - 5A	GMP22 - 2T · 5
		4.4 - 22A	GMP22 - 2T · 22
Connection without a screw ② - cables pass through CT holes	3-sensor (3 CT)	0.3 - 1.5A	GMP22 - 3T · 1.5
		1 - 5A	GMP22 - 3T · 5
		4.4 - 22A	GMP22 - 3T · 22
	3-sensor Reverse phase detection	0.3 - 1.5A	GMP22 - 3TR · 1.5
		1 - 5A	GMP22 - 3TR · 5
		4.4 - 22A	GMP22 - 3TR · 22

Certificate
CE, ULcUL

Ordering information

Specify catalog number

Front face configuration

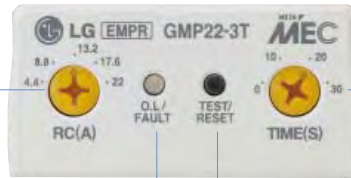

Current setting

0.3 ~ 1.5A
1 ~ 5A
4.4 ~ 22A

LED indicator

Operation status indication
- Normal operating
- Overload
- Phase unbalance
Trip cause indication
- Overcurrent
- Phase loss
- Reverse phase

Test/Reset button

Trip time setting

- 0 to 30 sec
- Set time is the trip time at 6 x set current



① To mount on 35mm DIN rail

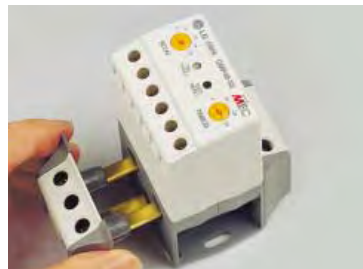

② Cable connection part can be modified between screw connection and passing CT hole

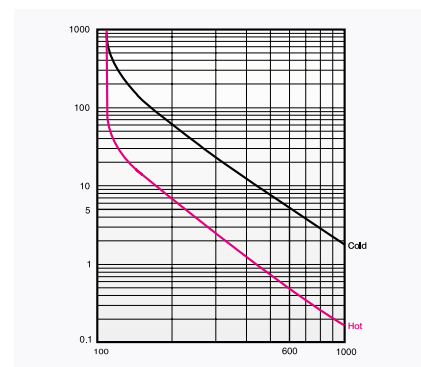

Technical information

Relay control voltage	100 to 260V AC 50/60Hz
Auxiliary contact	3A/250VAC at resistive load 1NO(97-98) + 1NC(95-96)
Setting tolerance	Current $\pm 5\%$ Time $\pm 5\%$ (or $\pm 0.5\text{sec}$)
Insulation resistance	Min 100M Ω at 500V DC
Impulse withstand voltage	1.2x50 μs 5kV (IEC1000-4-5)
Fast transient burst	2kV/5min (IEC1000-4-4)
Ambient temperature	-25 to 70°C for operation -30 to 80°C for storage
Humidity	30 to 90% RH

For more information

Drawings	➔ page 207
Connections	➔ page 193
Contactors	➔ page 26
Starters	➔ page 49
Bimetallic overload relay	➔ page 86
Operating curves	➔ page 155

Electronic overload relays

40A Inverse time characteristics



Description

- Wide and adjustable current range
- Adjustable trip time (trip class 5-10-15-20-30)
- Designed suitable for use with contactors
 - Directly mountable on the GM-32, 40 contactors
 - Separate mount versions are also available
 - Separately mountable on 35mm DIN rail or with screws
- 1NO+1NC trip contacts
- Manual reset as standard (Automatic reset optional)

Extended protective functions

Number of sensors		2CT	3CT	3CT
Types (GMP40-□)		(-2P, -2T, -2S)	(-3P, -3T, -3S)	(-3PR, -3TR, -3SR)
Functions	Overcurrent	✓	✓	✓
	Phase loss	✓	✓	✓
	Locked rotor	✓	✓	✓
	Phase unbalance		✓	✓
	Phase reversed			✓

Selection



Mount/Connection	Sensor	Setting range	Catalog No.
Directly on a contactor	2-sensor (2 CT)	4 - 20A	GMP40-2P · 20
		8 - 40A	GMP40-2P · 40
	3-sensor (3 CT)	4 - 20A	GMP40-3P · 20
		8 - 40A	GMP40-3P · 40
	3-sensor Reverse phase detection	4 - 20A	GMP40-3PR · 20
		8 - 40A	GMP40-3PR · 40
Separate mount ①	2-sensor (2 CT)	4 - 20A	GMP40-2S · 20
		8 - 40A	GMP40-2S · 40
Cable connection with a screw ②	3-sensor (3 CT)	4 - 20A	GMP40-3S · 20
		8 - 40A	GMP40-3S · 40
	3-sensor Reverse phase detection	4 - 20A	GMP40-3SR · 20
		8 - 40A	GMP40-3SR · 40
Separate mount ①	2-sensor (2 CT)	4 - 20A	GMP40-2T · 20
		8 - 40A	GMP40-2T · 40
Connection without a screw ②	3-sensor (3 CT)	4 - 20A	GMP40-3T · 20
		8 - 40A	GMP40-3T · 40
	3-sensor - cables pass through CT holes	4 - 20A	GMP40-3TR · 20
		8 - 40A	GMP40-3TR · 40

Certificate
CE, ULcUL

Ordering information

Specify catalog number

Front face configuration

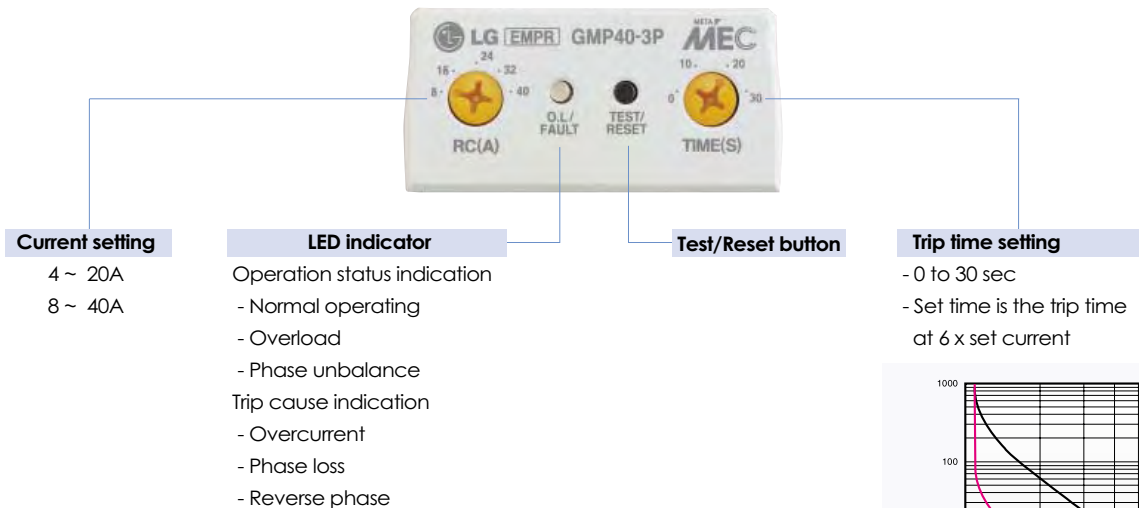

① To mount on 35mm DIN rail



② Cable connection part can be modified between screw connection and passing CT hole

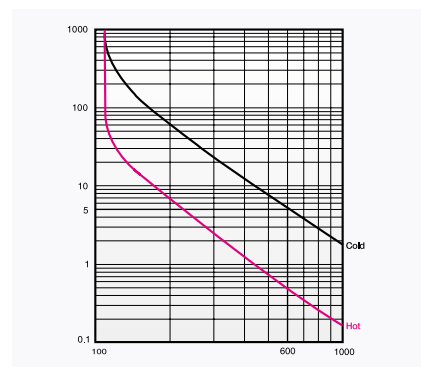

Technical information

Relay control voltage	100 to 260V AC 50/60Hz
Auxiliary contact	3A/250VAC at resistive load 1NO(97-98) + 1NC(95-96)
Setting tolerance	Current $\pm 5\%$ Time $\pm 5\%$ (or $\pm 0.5\text{sec}$)
Insulation resistance	Min 100M Ω at 500V DC
Impulse withstand voltage	1.2x50 μs 5kV (IEC1000-4-5)
Fast transient burst	2kV/5min (IEC1000-4-4)
Ambient temperature	-25 to 70°C for operation -30 to 80°C for storage
Humidity	30 to 90% RH

For more information

Drawings	➔ page 207
Connections	➔ page 193
Contactors	➔ page 28
Starters	➔ page 49
Bimetallic overload relay	➔ page 87
Operating curves	➔ page 155

Electronic overload relays

80A Inverse time characteristics



Description

- Wide and adjustable current range
- Adjustable trip time (trip class 5-10-15-20-30)
- Designed suitable for use with contactors GM-50, 65, 75, 85
- Separately mountable on 35mm DIN rail or with screws
- 1NO+1NC trip contacts
- Manual reset as standard (Automatic reset optional)
- Extended protective functions

Extended protective functions

Number of sensors		2CT	3CT	3CT
Types (GMP80-□)		(-2S)	(-3S)	(-3SR)
Functions	Overcurrent	✓	✓	✓
	Phase loss	✓	✓	✓
	Locked rotor	✓	✓	✓
	Phase unbalance		✓	✓
	Phase reversed			✓

Selection



Mount/Connection	Sensor	Setting range	Catalog No.
Separate mount	2-sensor (2 CT)	16 - 80A	GMP80-2S · 80
Cable connection with a screw	3-sensor (3 CT)	16 - 80A	GMP80-3S · 80
	3-sensor Reverse phase detection	16 - 80A	GMP80-3SR · 80

Technical information

Relay control voltage	100 to 260V AC 50/60Hz
Auxiliary contact	3A/250VAC at resistive load 1NO(97-98) + 1NC(95-96)
Setting tolerance	Current ± 5% Time ± 5% (or ±0.5sec)
Insulation resistance	Min 100MΩ at 500V DC
Impulse withstand voltage	1.2x50μs 5kV (IEC1000-4-5)
Fast transient burst	2kV/5min (IEC1000-4-4)
Ambient temperature	-25 to 70°C for operation -30 to 80°C for storage
Humidity	30 to 90% RH

For more information

- Drawings → page 207
- Connections → page 193
- Contactors → page 30
- Starters → page 49
- Bimetallic overload relay → page 88
- Operating curves → page 155

Ordering information

Specify catalog number

Certificate
CE, ULcUL

Front face configuration

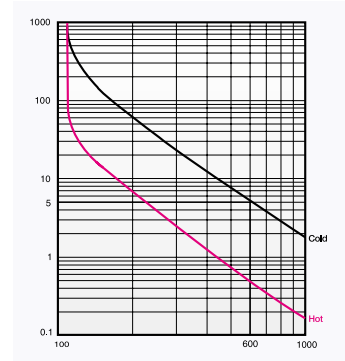
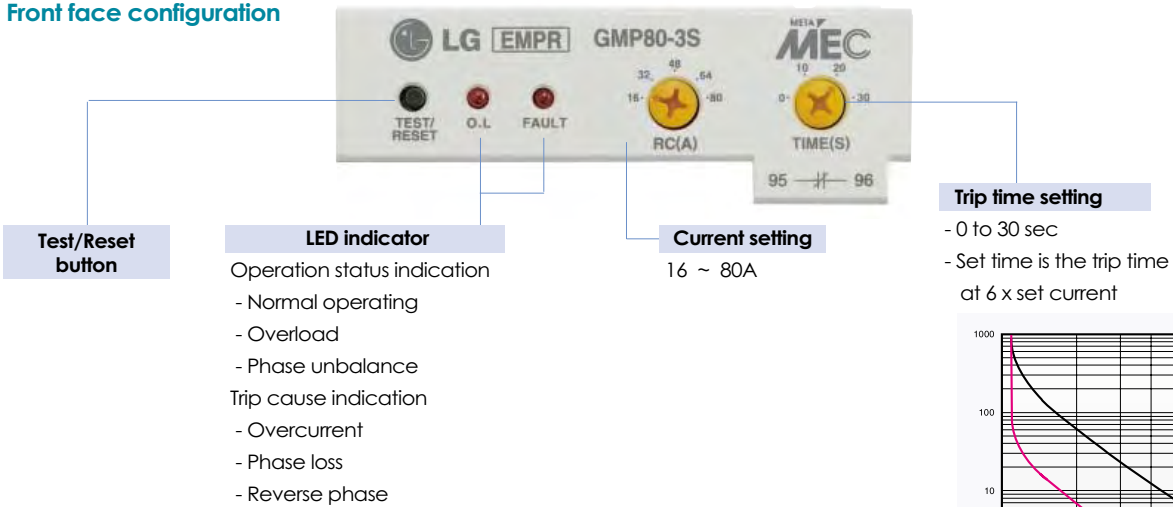

Indicate the cause of the fault by the LEDs

When it is tripped, you can check the causes of the fault by seeing the LED on it and you can troubleshoot the causes in a short time

Condition		Red O.L LED	Green Fault LED	Note
Operation	Normal	Off	Off	
	Over current	On & Off	Off	0.4 second interval
	Over current	On	Off	
Trip	Phase failure (3CT)	R On	On & Off	1 Times for 3second
		S On	On & Off	2 Times for 3second
		T On	On & Off	3 Times for 3second
	Phase failure(2CT)	On & Off	Protect 2phases of 3phases, trips within 3sec.	
	Reverse phase(3CT)	On & Off	On & Off	One after the other

Technical information

Relay control voltage	100 to 260V AC 50/60Hz
Auxiliary contact	3A/250VAC at resistive load
	1NO(97-98) + 1NC(95-96)
Setting tolerance	Current $\pm 5\%$
	Time $\pm 5\%$ (or $\pm 0.5\text{sec}$)
Insulation resistance	Min 100M Ω at 500V DC
Impulse withstand voltage	1.2x50 μs 5kV (IEC1000-4-5)
Fast transient burst	2kV/5min (IEC1000-4-4)
Ambient temperature	-25 to 70°C for operation
	-30 to 80°C for storage
Humidity	30 to 90% RH

Electronic overload relays

60A Definite time characteristics



Description

- Small size, economical
- Delay time setting in starting and operation
- Over current, phase failure protection
- Definite time characteristics
- Wide current setting range
- Screw or Din-rail mounting

Extended protective functions

Number of sensors		2CT
Types (GMP-60T)		
Functions	Overcurrent	✓
	Phase loss	✓ Δ Note1)
	Locked rotor	✓
	Phase unbalance	
	Phase reversed	

Ratings (Tunnel type)

Model		GMP60T
Type		Tunnel type
No. of CT		2
Current setting range(A)		0.5~6
		3~30
		5~60
Operating time characteristics		Definite time characteristics
Time setting (sec.)	Starting time	0.2~30
	Operating time	0.2~15
	Reset time	Manual reset
Allowable error	Current	$\pm 5\%$
	Time	$\pm 5\%$ (or ± 0.5 sec.)
Control power	Voltage	180~260V (110V / 440V) Note2)
	Frequency	50 / 60Hz
Aux. s/w	Contact	1SPDT (1c)
	Ratings	5A 250Vac, resistive load
	Operation	95 $\overline{}$ 96close
Insulation resistance		Min. 50M Ω at 500Vdc
Surge insurance(IEC 1000-4-5)		7kV(6times for 1min. Interval)
Fast transient burst(IEC 1000-4-4)		2.5kV/5min.
Environment	Operation	-25~70°C
	Storage	-50~80°C
Relative humidity		46~85 RH(No freezing)
Trip indicator		LED
Dimension(mm) W x H x D		72 x 63 x 69
Mounting type		Separate mount(Screw & Din-rail)
Applied MC		GMC-9, 12, 18, 32, 40, 50
Certification		UL, CUL, CE

Note 1) Under phase failure condition over current flows
The EMPR tripped if it is over the setting over current

Note 2) () are optional specifications

Contact configuration

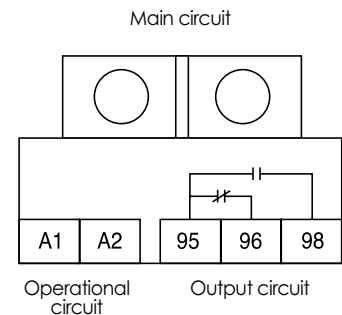

Tunnel type EMPR protects the current under 0.1A

- The tunnel type EMPR with 0.5~6A nominal current, can detect the current under 0.1A

If we increase the number of times of a wire pass through the CT (Tunnel), the EMPR can detect the lower current

No. of times to pass through	Current setting range
1	0.5~6
2	0.25~3
3	0.17~2
4	0.12~1.5